

### Scaled Pulse Output



**SC500**  
Remote Mount



**SC510**  
Local Mount

The FLOMEC® Scaled Pulse Module is a switch-programmable multi-stage counter/divider with multiple inputs. The module provides selectable K-factor to convert input frequency to scaled pulse output. The SC500 connects via a 20 foot input cable. The SC510 connects directly to the 1 inch MNPT conduit connector.

Choose the 8 when a local mount is needed on the G series.

### SC500/SC510 – SPECIFICATIONS

<b>Accuracy:</b>	± 0.1% of reading
<b>Power Source:</b>	DC powered 5 to 30 VDC
<b>Input Signal:</b>	Hall Effect, Reed Switch or Open Collector (NPN) or Sine Wave
<b>Output Signal:</b>	Open Collector (NPN)
<b>Frequency Range:</b>	Coil, HF = 0-1500 Hz; LF = 0-150 Hz
<b>Operating Temperature:</b>	-40° F to +185° F (-40° C to +85° C)
<b>Cable:</b>	<i>Remote:</i> 20 ft. (6 m), 3-conductor, tinned drain wire, 22 AWG, PVC jacket .212 dia. Ref. Belden 9363. <i>Local:</i> No cable provided
<b>Mechanical Connections:</b>	<i>Remote:</i> Wall or pipe mountable with standard U-bolts. <i>Local:</i> Unit is mounted to meter body, 1" NPT.
<b>Electrical Connections:</b>	<i>Remote:</i> Two strain relief ports <i>Local:</i> One strain relief port; one threaded plug

### ACCURACY: ±0.1% READING

#### Features and Benefits:

- ✓ Converts input frequency to scaled pulse output.
- ✓ Provides communication with process control equipment.
- ✓ Works with G Series, G2 and A1 Turbine Meters, OM and DP Meters.
- ✓ Remote model mounts on pipe or wall.

### Electronic Choice - Local & Remote (Dimensions can vary by model.)

#### Local Model (510 Series)

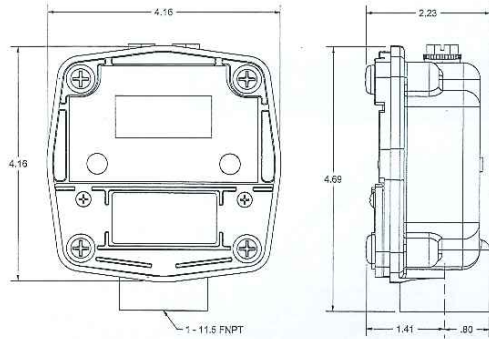

Length inches (mm)	Height inches (mm)	Width inches (mm)
2.23 (57)	4.69 (119)	4.16 (106)

#### Remote Model (500 Series)

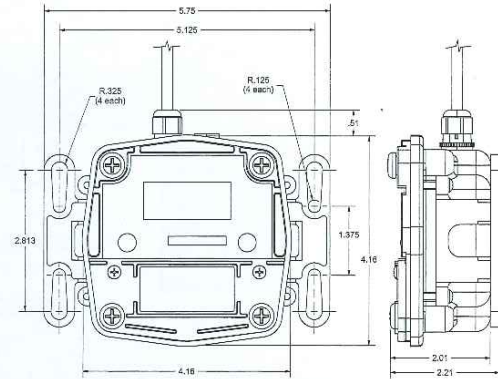









Length* inches (mm)	Height † inches (mm)	Width* inches (mm)
2.21 (56)	4.67 (119)	5.75 (146)

\* Includes Mounting Bracket  
† Includes Strain Relief

At Great Plains Industries, we've been building rugged, reliable, liquid flowmeters for over 35 years. The GPI Industrial Meter family includes a full line of Precision and Industrial Turbine meters plus Oval Gear meters in various materials, sizes and fitting options.

We design products to meet the needs of our customers. This includes maintaining appropriate, industry standard approvals. Approvals vary by product line and may be dependent on meter application.

The Approval symbol is listed under product specifications on individual product pages. If no approval mark is found, check the chart to the right. For details about specific "Approvals" refer to the chart.

<p><b>3-A</b></p>	<p><b>3-A Sanitary Standards, Inc.</b> "Flowmeters for Milk and Milk Products, Number 28-03" for GSCPS Models and L Option Meters.</p>
<p><b>ATEX</b> </p>	<p><b>Ex II 1 G</b> Per 94/9/EC.</p>
<p></p>	<p>Product reviewed for EMC Directive 2004/108/EC. Includes: Euro Norms 61000-6-2 (2005) and 61000-6-3 (2007) on A1 and G2 Series Meters. Note: For <b>Oval Gear Meters</b>, the CE Approval is applied when meter is part of a system.</p>
<p></p>	<p><b>Factory Mutual Approved</b> Intrinsically Safe for Class I, II, III, Division 1, All Groups. Nonincendive for Class I, II, III, Division 2 Groups A, B, C, D, F, G.</p>
<p></p>	<p><b>Factory Mutual Approved</b> Class 1, Div. 1, Group D (01A31GM Only)</p>
<p></p>	<p><b>Factory Mutual Approved</b> Intrinsically safe for Class I &amp; II, Div. 1, Groups A, B, C, D, E, F &amp; G, T6 Ta=-40° C to 60° C hazardous locations, and for use in Class I, Zone 0 as Ex is IIC T6 Ta=-40° C to 60° C.</p>
<p></p>	<p><b>Federal Communication Commission</b> Industry Canada Approval Class B; digital service, part 15 of FCC Rules.</p>
<p></p>	<p><b>Ex ia IIC T6 Ta=60° C</b></p>
<p><b>IP44/IP54/IP66</b></p>	<p><b>Ingress Protection Code</b> IP44 (Greater than 1 mm and splashed water); IP54 (Dust protected and splashed water); IP66 (Dust-tight and heavy seas).</p>
<p><b>IP/NEMA</b></p>	<p>Pulse versions of <b>Oval Gear Meters</b> have enclosure ratings that vary from IP54 / NEMA 13 to IP66 / NEMA 16 depending on the application.</p>
<p><b>NEMA</b> <b>4</b></p>	<p>NEMA Requirements: Enclosure constructed for indoor or outdoor use to provide a degree of protection to personnel against incidental contact with the enclosed equipment. Protection against falling dirt, rain, sleet, snow, windblown dust, splashing or hose directed water that will be undamaged by the external formation of ice on the enclosure. <i>GPI products are tested to NEMA requirements.</i></p>
<p></p>	<p>Restriction of Hazardous Substances Directive 2002/95/EC and 2011/65/EU</p>
<p></p>	<p>Indicates that the product was tested and has met the certification requirements for electrical, plumbing and/or mechanical products.</p>